

Genie® Z®-45/25J DC

Specifications

Models	Z-45/25J DC	
Measurements	US	Metric
Working height max. ⁽¹⁾	51 ft 9 in	15.94 m
Platform height max.	45 ft 9 in	13.94 m
Horizontal reach max.	25 ft 1 in	7.65 m
Up and over clearance max.	23 ft 9 in	7.24 m
A Platform length	2 ft 6 in	0.76 m
B Platform width	6 ft	1.83 m
C Height - stowed (tires)	6 ft 7 in	2.00 m
D Length - stowed (tires)	22 ft 5 in	6.83 m
E Width	5 ft 10.25 in	1.79 m
F Wheelbase	6 ft 8 in	2.03 m
G Ground clearance - center	9.5 in	0.24 m

Productivity

Lift capacity max. - unrestricted	500 lb	227 kg
Platform rotation	160°	
Jib length	5 ft	1.52 m
Vertical jib rotation	135°	
Turntable rotation	355°	
Turntable tailswing	0 in	0 cm
Drive speed - stowed ⁽²⁾	3.0 mph	4.8 km/h
Drive speed - raised	0.61 mph	1.0 km/h
Gradeability - stowed ⁽²⁾	30%	
Tilt sensor activation (front to back/side to side)	2.5° - 4.5° / 4.5°	
Turning radius - inside/outside	6 ft / 14 ft	1.8 m / 4.27 m
Tires (solid, non-marking)	9×14.5 in	0.23×0.37 m

Power

Power	48V DC (8×6V 350Ah)	
Auxiliary power unit	24V DC	
Hydraulic tank capacity	8 gal	30.3 L

Weight⁽³⁾ and Floor Loading⁽⁴⁾

Weight (tires)	16,315 lb	7,400 kg
Tire contact pressure	100 psi	689 kPa
Occupied floor pressure (tires)	315 psf	15.08 kPa

Sound and Vibration Levels

Sound Pressure level (ground workstation)	< 70 dBA	
Sound Pressure level (platform workstation)	< 70 dBA	
Vibrations	8 ft 2 in/s ²	2.5 m/s ²

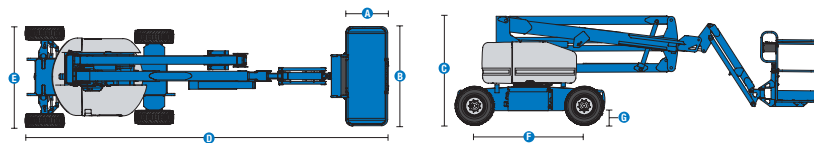

Range of motion Z-45/25J DC

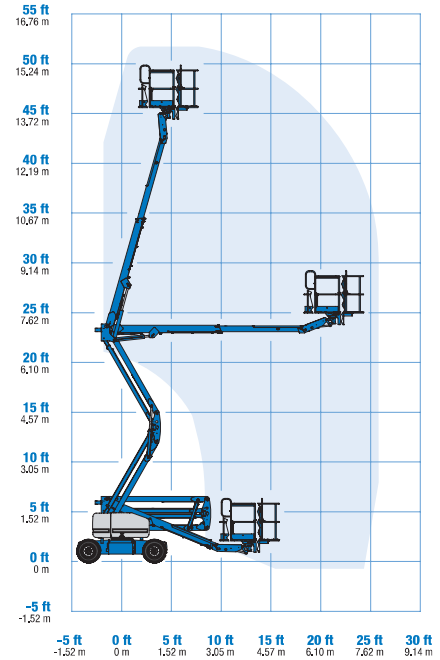

(1) The metric equivalent of working height adds 2 m to platform height. The imperial equivalent adds 6 ft to platform height.
 (2) Gradeability applies to driving on slopes and may vary depending on options and machine configurations. See operator's manual for details regarding slope ratings.
 (3) Weight refers to standard configuration and may vary depending on options and/or country standards.
 (4) Floor loading information is approximate and may vary depending on options and machine configurations. It should be used only with adequate safety factors.

Genie® Z®-45/25J DC

SKU: Standard Model

- **Z45JDC01AE0050:** Z-45/25J DC, DC Power, 2WD

* Build to Order

Option availability		S	S+	BtO
Power	Standard FLA flooded lead acid battery	✓	✓	✓
	AGM Maintenance-free batteries			○
	Battery charge indicator (BCI)			○
	Low voltage interrupt (LVI) with battery charge indicator (BCI)			○
	Power Inverter, 800W, 120V AC, 60Hz			○
Platform	3ft 10in/1.17m steel platform			○
	6ft/1.83m dual-entry platform with side swing gate	✓	✓	✓
	Air line to platform			○
	Aircraft protection kit			○
	Control box covers			○
	Lift Guard Half Mesh panels			○
	Light Package: drive and work lights			○
	Platform auxiliary top rail			○
	AC Power cord to platform	✓	✓	✓
	Drive enable system	✓	✓	✓
	Horn	✓	✓	✓
	LCD display	✓	✓	✓
	Lift Guard Contact Alarm	✓	✓	✓
	Lift Tools Work Tray	✓	✓	✓
	Platform load sense system	✓	✓	✓
	Proportional controls	✓	✓	✓
	Self-leveling platform	✓	✓	✓
Travel alarm package: flashing beacons, descent, travel and tilt alarms	✓	✓	✓	
Chassis	Lift Connect Telematics			○
	Lift Connect with Access Manager upgrade			○
	Biodegradable hydraulic oil			○
	Cold weather hydraulic oil			○
	Fire resistant hydraulic oil (45/25J DC)			○
	Industrial, foam-filled non-marking tires			○
	Industrial, foam-filled tires	✓	✓	✓
	Hostile environment kit			○
	Tow package			○
	Chassis tilt drive function cut-out	✓	✓	✓
	Dual parallelogram lift linkage	✓	✓	✓
Hour meter	✓	✓	✓	
Zero tail swing	✓	✓	✓	

- S Standard
- S+ Standard +
- BtO Build to Order
- ✓ Standard Features
- Options



Quiet Operation



Zero Tailswing

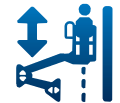

Dual Parallel Linkage



Genie Genuine Accessories⁽¹⁾

- Lift Tools Productivity Tools
- Tech Pro Link Handheld Device

(1) More accessories available from Genie Genuine Parts.

Distributed By:



Equipinc AWP Sdn Bhd (1077085-A)

31, Jalan Serendah 26/39, i-Parc 2 Seksyen 26,
40400 Shah Alam, Selangor.
T +(603) 5103 0939/ 5103 2685
F +(603) 5103 2839
H/P +(6012) 377 3571 (Zun), +(6012) 639 2731 (Tan)
E awpsales@equip-inc.com

Product specifications are subject to change without notice or obligation. Photographs and/or drawings herein are for illustrative purposes only. Refer to the appropriate Operator's Manual for instructions on proper equipment use. Failure to follow instructions in the Operator's Manual may result in serious injury or death. The only warranty applicable to our equipment is the standard written warranty applicable to the particular product and sale and we make no other warranty, express or implied. Products and services listed may be trademarks, service marks or trade names of Terex Corporation and/or their subsidiaries in the USA and many other countries. Terex, Genie, Quality By Design, Xtra Capacity, Lift Power, Lift Guard, Lift Tools, Lift Connect and Tech Pro Link are registered trademarks of Terex Corporation or its subsidiaries.

04/22

